



**SUPPLEMENTAL BID BULLETIN**  
**BRN-BAC-2026-007**

June 23, 2026

TO : ALL QUALIFIED/PROSPECTIVE BIDDERS

SUBJECT : CLARIFICATIONS TO BIDDING DOCUMENTS FROM THE PRE-BID CONFERENCE HELD  
LAST JUNE 17, 2026

PROJECTS : 1 Labor and Supply of Materials & Equipment for the Construction of Distribution  
Facilities of Twelve (12) Sitios under Sitio Electrification Program (SEP) 2026  
2 Installation and Supply of Housewiring Materials intended for the Two Hundred  
Sixty-Two (262) Households under Sitio Electrification Program (SEP) 2026

In accordance with the provisions outlined in Clause #10 of the Instruction to Bidders regarding **Clarification and Amendment of Bidding Documents**, it is stated that "Bidders who have purchased the Bidding Documents may request for clarification(s) on any part of the Bidding Documents or for an interpretation. That, Supplemental/Bid Bulletins may be issued upon the Procuring Entity's initiative for purposes of clarifying or modifying any provision of the Bidding Documents not later than seven (7) calendar days before the deadline for the submission and receipt of Bids".

Consequently, this Bid Bulletin has been issued to address queries and clarifications that were discussed and agreed upon by the members of the Bids and Awards Committee (BAC) and prospective bidders during the Pre-Bid Conference held on June 17, 2026.

**I. OPENING OF BIDS**

- The Opening of Bids will be held on **June 29, 2026 (Monday), at 11:00 A.M.** Attendees may participate either in person at the SURNECO Main Office, located within the SURNECO Compound Espina Extension, Brgy. Taft, Surigao City, or virtually through the Zoom platform. Please refer to the location map provided below for detailed physical direction.

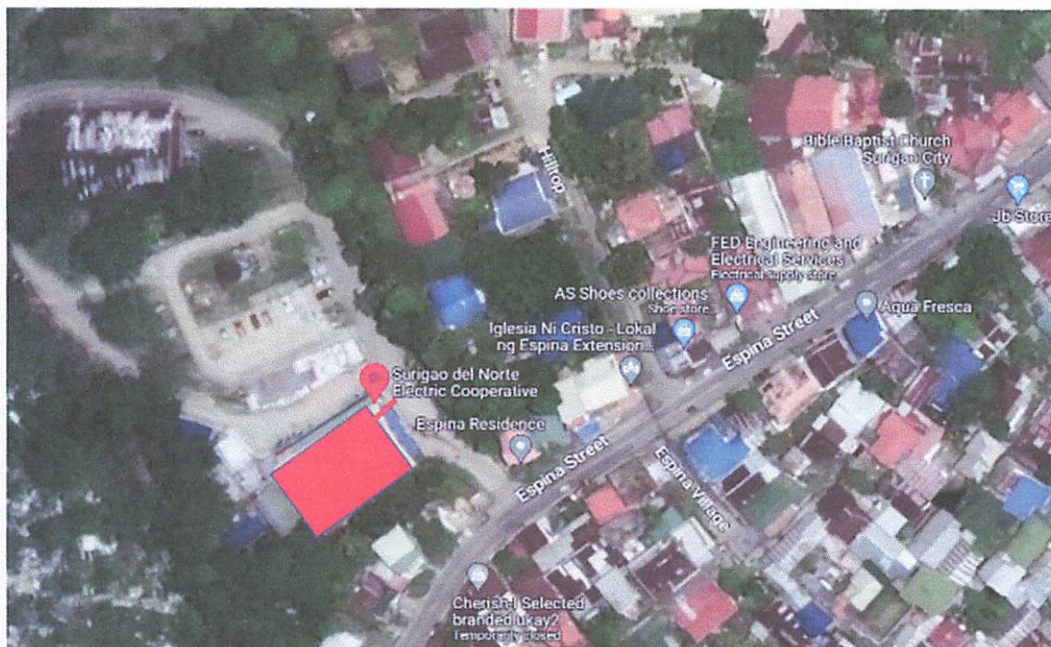

II. SECTION II – ELIGIBILITY REQUIREMENTS

**ELIGIBILITY REQUIREMENTS (CLASS “A” DOCUMENTS) (ENVELOPE1)**

**1. LEGAL DOCUMENTS (FOLDER 1, ENVELOPE 1)**

- a. Proof of Vat Payment for the past six (6) months shall be from **October 2025 to March 2026 (4<sup>th</sup> quarter of 2025 and 1<sup>st</sup> quarter of 2026)** under Legal Documents Folder 1, Envelope 1 Number 6 sub-section (a);

**2. TECHNICAL DOCUMENTS (FOLDER 1, ENVELOPE 2)**

1. For BAC Form No. 6 & 7 – Please provide the needed details as prescribed in the bidding documents illustrated below:

Name of Contract	a.) Owner’s Name b.) Address c.) Telephone Nos.	Nature of Work	Bidder’s Role	a.) Amount at award b.) Amount at Completion c.) Duration	a.) Date Awarded b.) Contract Effectivity c.) Date Completed
------------------	---	----------------	---------------	---	--

**NOTE: FAILURE TO DO SO SHALL BE SUBJECT FOR DISQUALIFICATION**

2. For BAC Form No. 6 & 7 – Completed and On-going projects must be related/same to the Lots to be bid **(covering the period from June 2016 to June 2026)**;

**NOTE: LUMPING OF DIFFERENT LIST OF PROJECTS IS PROHIBITED AND SHALL BE SUBJECT FOR DISQUALIFICATION**

3. For BAC Form No. 6 – list of supporting documents shall remain the same and must be completely attached, as follows:

- Notice of Award
- Notice to Proceed issued by the owner
- Certificate of Accomplishment signed by the owner or authorized representative or Check Vouchers with attached receipts and Purchase Orders.

4. For BAC Form No. 7 – must attach the Certificate of Completion or Certificate of Completion and Acceptance.

5. **The Prospective bidder must have completed a Single Largest Completed Contract (SLCC), that is similar to the contract to be bid, and whose value, adjusted to current prices using the NEA price indices, must be at least fifty percent (50%) of the Approved Budget Cost (ABC) to be bid.** Further please indicate the Single Largest Completed Contract (SLCC) on a separate BAC Form which is **BAC Form No. 7-A, marked as ANNEX B (Soft Copy Attached)** and attach the Certificate of Completion or Certificate of Completion and Acceptance.

**NOTE: BAC FORM NOS. 6, 7 & 7-A MUST HAVE DURATION FROM JUNE 2016 TO JUNE 2026.**

6. PCAB license – (Philippines Contractors’ Accreditation Board) per Board Resolution No. 201, series of 2017, please find the minimum license classification and category below.

**SEP – Distribution Line**

Classification	Size Range	License Category	Single Largest Project (₱)
SP-EE (Electrical Work)	Medium A	B	Above 15 Million up to 75 Million

### SEP – Housewiring

Classification	Size Range	License Category	Single Largest Project (₱)
SP-EE (Electrical Work)	Small B	C & D	≤ 15 Million

### 3. FINANCIAL DOCUMENTS (FOLDER 1, ENVELOPE 3)

1. Complete set of audited financial statements required **must be calendar year 2025**, and stamped “received” by the Bureau of Internal Revenue (BIR) or its duly accredited and authorized institutions. **Audited Financial Statement filed electronically shall no longer be required to be stamped “received” in accordance with BIR Revenue Memorandum Circular No. 034-2025, however the Tax Filing Reference Number (FRN) or the Tax Return Receipt Confirmation (TRRC) must be included as proof of filing.**

- 5.5 The computation of a bidder’s NFCC must be at least equal to the ABC to be bid, calculated as follows:

NFCC = [(Current assets minus current liabilities) (15)] minus the value of all outstanding or uncompleted portions of the projects under ongoing contracts, including awarded contracts yet to be started, coinciding with the procurement project to be bid;

Provided, that a different formula may be adopted subject to the recommendation of the Procuring Entity, which shall be submitted to the GPPB for consideration. The value of the domestic bidder’s current assets and current liabilities shall be based on the latest AFS submitted to the BIR. For the purpose of computing the foreign bidders' NFCC, the value of the current assets and current liabilities shall be based on their AFS prepared in accordance with international financial reporting standards.

### III. SECTION III – INSTRUCTION TO BIDDERS

2. Reminding on Subsections:

- 13.1 **Alternative Bids shall be rejected and considered as failed.** For this purpose, alternative bid is an offer made by a Bidder in addition or as a substitute to its original bid which may be included as part of its original bid or submitted separately therewith for purposes of bidding. A bid with options is considered an alternative bid regardless of whether said bid proposal is contained in a single envelope or submitted in two (2) or more separate bid envelopes.

- 17.3 Bid Security must be deposited to the bank account provided below at least three (3) days before the scheduled Opening of Bids. Validated deposit slip must be inserted under Folder 1 – Technical Proposal of the soft and hard copies.

Bank : Landbank – Surigao Luna Branch  
Account Name : Surigao del Norte Electric Cooperative, Inc.  
Account Number : 595-211-0260

- 19.6 Each Bidder shall submit **four (4) sets of bid documents (1 original and 3 Certified True Copy from the Original Remarks)**, for the first and second components of its bid. The original and the photocopies of the Bid shall be typed or written in indelible ink and shall be signed by the bidder or its duly authorized representative/s.

**NOTE: In the event that a bidder participates in both lots, they are required to submit the first and second components of each lot separately.**

20 Section 20 of the bidding documents shall be amended and read as follows

**"Deadline of Submission of Bids.** Last day for the submission of the hard and soft copies of the bid is until **11:00 A.M.** of June 29, 2026. **(See Section 3, Instruction to Bidders Clause 19.1 – 19.3)."**

21 Late Bids. Any bid submitted after the deadline for submission and receipt of bids prescribed by the SURNECO, pursuant to Invitation to Bid Clause 20, shall be declared **"Late"** and shall not be accepted by the SURNECO through Secretariat.

30.3 The SURNECO shall enter into contract with the successful Bidder within the same five (5) working day(s) period provided that all the documentary requirements are complied with/upon availability of funds.

For your information and ready reference.

Thank you.

**THE BIDS & AWARDS COMMITTEE**

  
**ENGR. MICHAEL O. LUMANCAS**  
CorPlan Manager / BAC Chairperson

  
**ENGR. ALLAN N. CARDINES**  
CSD Manager/ Vice-Chairperson

  
**ENGR. SOHMAR DAVE C. BECERRO**  
Operations & Maintenance Supervisor/Member

  
**MS. MARIA GEMMA P. ENSOMO**  
HRMDD Manager/ Member

  
**ENGR. JAYSON R. ROJO**  
OIC-Sub-Area Office I/Member

ANNEX A – STEEL POLE NUMBER DESIGN – MODEL

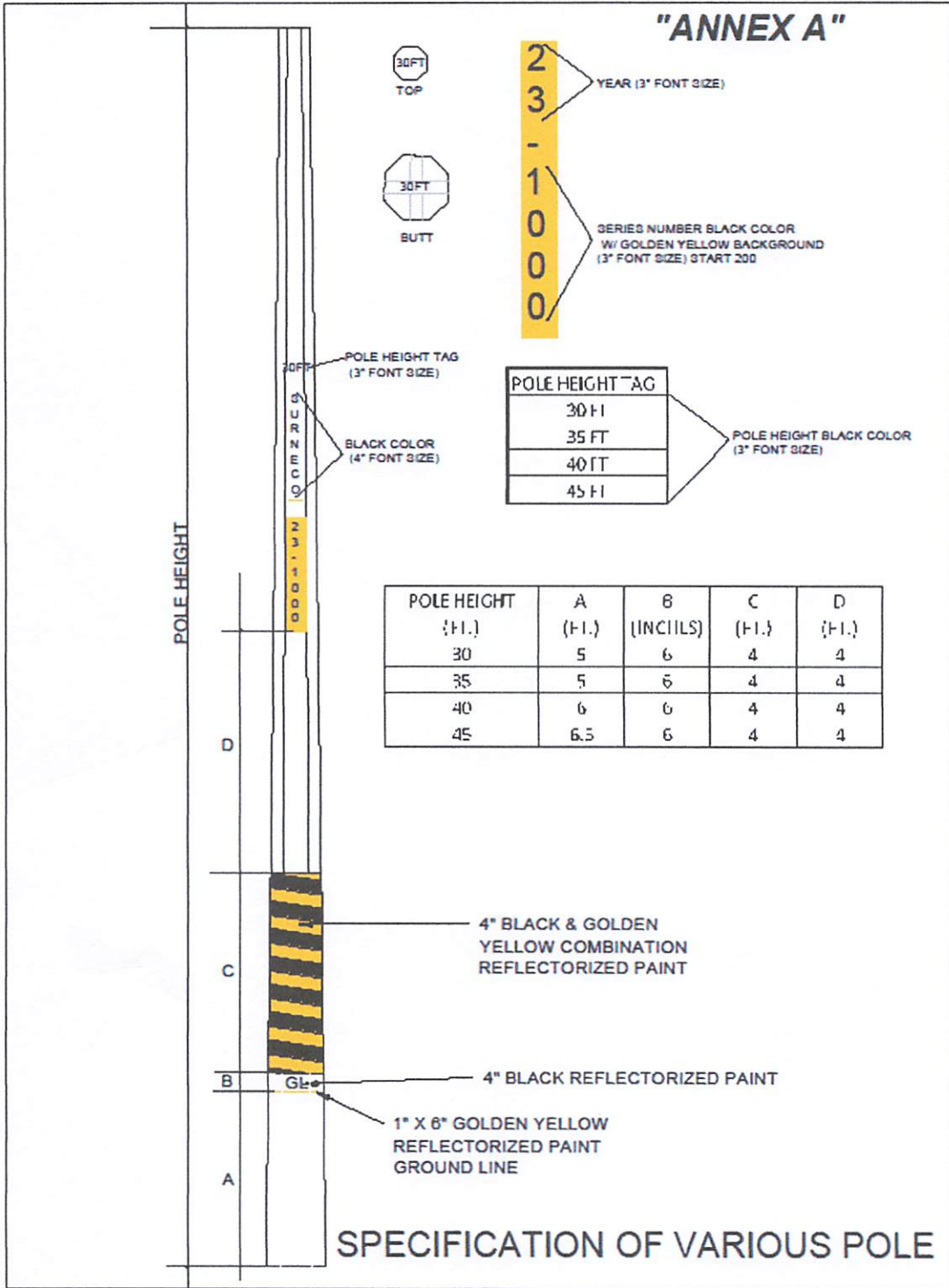

ANNEX B – TRANSFORMER TAGGING

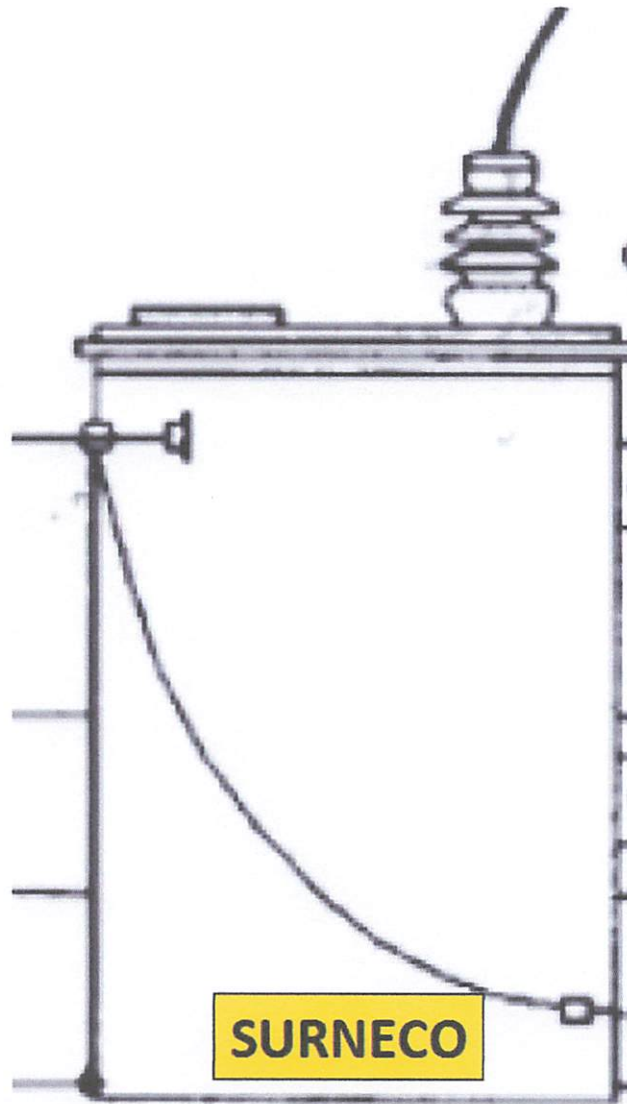

**ANNEX C – REVISED BAC FORM**

**BAC Form No.: 10**

**PRICE FORM**

Name of Bidder : \_\_\_\_\_

Address : \_\_\_\_\_

Our offered price for the **LABOR AND SUPPLY OF MATERIALS & EQUIPMENT FOR THE CONSTRUCTION OF DISTRIBUTION FACILITIES OF TWELVE (12) SITIOS UNDER SEP 2026** is:

**Amount in Words:** \_\_\_\_\_

**(Php \_\_\_\_\_)** inclusive of VAT, duties and other levies and incidental expenses.

Please refer to the details of pricing.

I certify that the above information is true and correct.

Submitted:

\_\_\_\_\_  
(Print over signature of Authorized Representative/Owner/Manager)

**DETAILS**

No.	Name of Sitio/Purok	Material Cost	Labor Cost	Freight and Handling Cost	Sub-Total
1	Lujo, Lapinigan, Claver				
2	Purok 1-B, Danao, Surigao City				
3	Purok 3-A, Danao, Surigao City				
4	Purok 2-A, Mabini, Surigao City				
5	Purok Malipayon, San Isidro, Gigaquit, Surigao del Norte				
6	Capitol, Sico-Sico, Gigaquit, Surigao del Norte				
7	Lukaran, Sico-Sico, Gigaquit, Surigao del Norte				
8	Purok Rosal, Quezon, Mainit, Surigao del Norte				
9	Purok 1, Bad-as, Placer, Surigao del Norte				
10	San Francisco Tribal Village, Magtangale, San Francisco, Surigao del Norte				
11	Brgy. Site, Gacepan, Sison, Surigao del Norte				
12	Purok 2 and 5, Marga, Tubod, Surigao del Norte				
<b>TOTAL</b>					

**ANNEX D – REVISED BAC FORM**

**BAC Form No.: 10**

**PRICE FORM**

Name of Bidder : \_\_\_\_\_

Address : \_\_\_\_\_

Our offered price for the **INSTALLATION AND SUPPLY OF HOUSEWIRING MATERIALS AND SUPPLY OF KILOWATT-HOUR METERS, SERVICE DROP WIRES AND COMPRESSION CONNECTORS INTENDED FOR THE TWO HUNDRED SIXTY-TWO (262) HOUSEHOLDS OF THE TWELVE (12) SITIOS UNDER SEP 2026** is:

**Amount in Words:** \_\_\_\_\_

(Php \_\_\_\_\_) inclusive of VAT, duties and other levies and incidental expenses.

Please refer to the details of pricing.

I certify that the above information is true and correct.

Submitted:

\_\_\_\_\_  
(Print over signature of Authorized Representative/Owner/Manager)

**DETAILS**

<b>Labor and Supply of Housewiring Materials for the 12 sitios under SEP</b>					
<b>MATERIAL COST</b>					
<b>No.</b>	<b>Description</b>	<b>Quantity</b>	<b>Unit</b>	<b>Cost per Unit (Php)</b>	<b>Sub-Total (Php)</b>
1	Bolt-on type with enclosure Circuit Breaker (15 amps)	262	sets		
2	Receptacles (PVC Type 2x2)	524	pcs.		
3	CFL Bulb (15W)	524	pcs.		
4	Surface Mounted Tumbler Switch	524	pcs.		
5	Surface Mounted Convenience Outlet (2 gang)	262	pcs.		
6	Junction Box 4x4 depth type (plastic with cover)	524	sets		
7	PDX Wire #10, with sequential numbering	1,310	meters		
8	PDX Wire #12, with sequential numbering	2,620	meters		
9	PDX Wire #14, with sequential numbering	2,620	meters		
10	Electrical Tape (Big) <ul style="list-style-type: none"> <li>• Size: 19mm x 6m x 0.155mm</li> <li>• Good Adhesion</li> <li>• UV Resistant</li> <li>• Flame Retardant</li> <li>• Elongation: 200%</li> </ul>	262	pcs.		
11	Staple Wire (No.1) Insulated	7,860	pcs.		
12	¾" Electric Metallic Tubing (EMT) Service Entrance Cap	262	pcs.		
13	¾" Electric Metallic Tubing (EMT) Line Box (LB) Conduit	262	pcs.		

14	¾" Electric Metallic Tubing (EMT) Pipe (Length)	262	pcs.		
15	¾" Electric Metallic Tubing (EMT) Elbow	786	pcs.		
16	1" x ¾" Electric Metallic Tubing (EMT) Reducer	524	pcs.		
17	¾" Electric Metallic Tubing (EMT) Connector	1,310	pcs.		
18	¾" Electric Metallic Tubing (EMT) Coupling	1,048	pcs.		
19	PVC C-Clamp for ¾" Electric Metallic Tubing (EMT)	1,572	pcs.		
20	Ground Rod, Steel, Galvanized, 5/8" x 10', Hot Dip Galvanized	262	pcs.		
21	Wire, Grounding, Aluminum Alloy, either Stranded or Solid, #6 AWG	786	meters		
22	Clamp, Ground Rod for 5/8" Steel Rod (tamperproof)	262	pcs.		

**TOTAL MATERIAL COST (A)**

**LABOR COST**

No.	Description	Quantity		Cost of Labor per Household (PhP)	Sub-Total (PhP)
1	Labor	262	HH		

**TOTAL LABOR COST (B)**

**Supply of KWHR Meter, Service Drop Wire and Compression Connector**

No.	Description	Quantity	Unit	Per Unit Cost (PhP)	Sub-Total (PhP)
1	<p>Single Phase, Class 1, 240 Volts, 10 (60) Ampere, Electronic Meter, Bottom Connected and with transparent meter cover.</p> <ul style="list-style-type: none"> <li>• With built-in back-up battery intended for supplying power to the LCD display during power outage</li> <li>• LCD display must show five integer number and a one decimal number.</li> <li>• With instantaneous display of volt, current and kilowatt</li> <li>• With line terminal barrier protection</li> <li>• Direct type copper terminal jumpers</li> <li>• Terminal connector and screw is built all with copper brass</li> <li>• The meter cover must be reinforced with barrier protection for the rain water</li> <li>• With reinforced glass fiber terminal cover that fits with the barrier protection of the meter cover for additional water protection</li> <li>• Distance from line take off terminal cover to terminal connector is 1.5 inches</li> <li>• With ready access slot at the side of the terminal cover for line wires to enter</li> <li>• With certified ERC acceptance testing result and seal.</li> </ul>	262	pcs		
2	Conductor, Duplex, #6 AWG, with sequential numbering	8,190	mtrs.		
3	Connector, Compression, YHO, No. 6 – No. 2 ACSR Run To No. 6 – No. 2	546	pcs.		

					TOTAL COST (C)	
No.	Description	Quantity	Unit	Freight and Handling Cost per Household (PhP)	Sub-Total (PhP)	
1	Freight and Handling	262	HH			
					TOTAL COST (D)	
					GRAND TOTAL (A +B + C + D)	